

# FENCE 150

BARRIERE DI PROTEZIONE PER SCAFFALI  
RACK END BARRIER

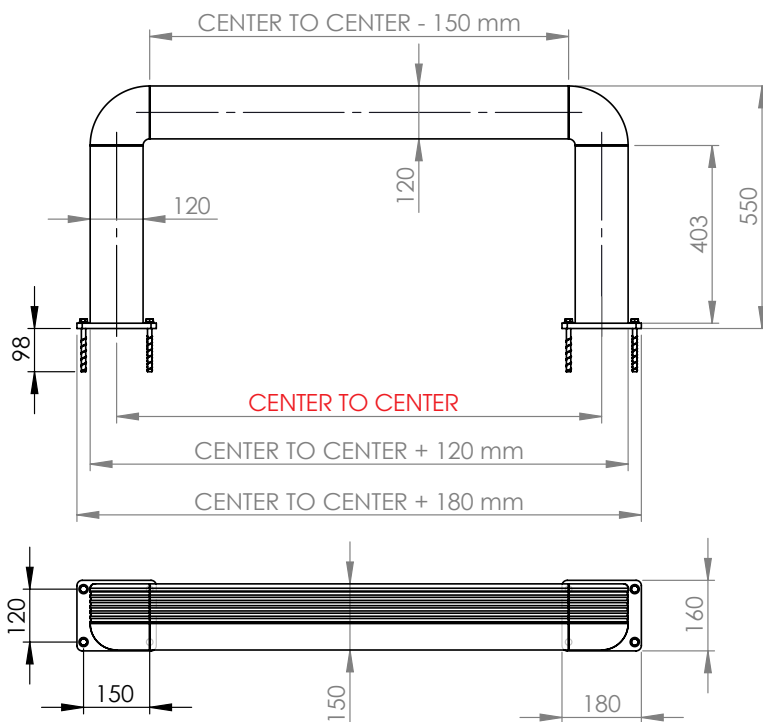
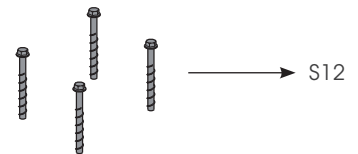
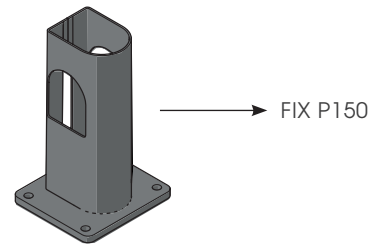
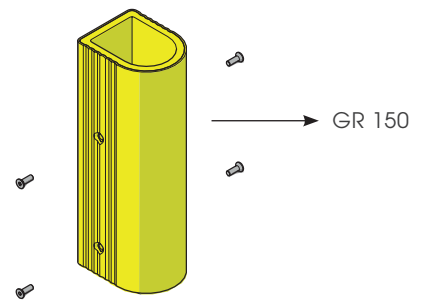
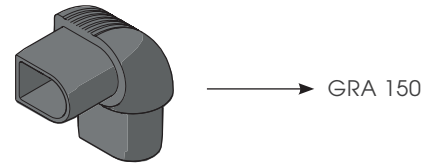
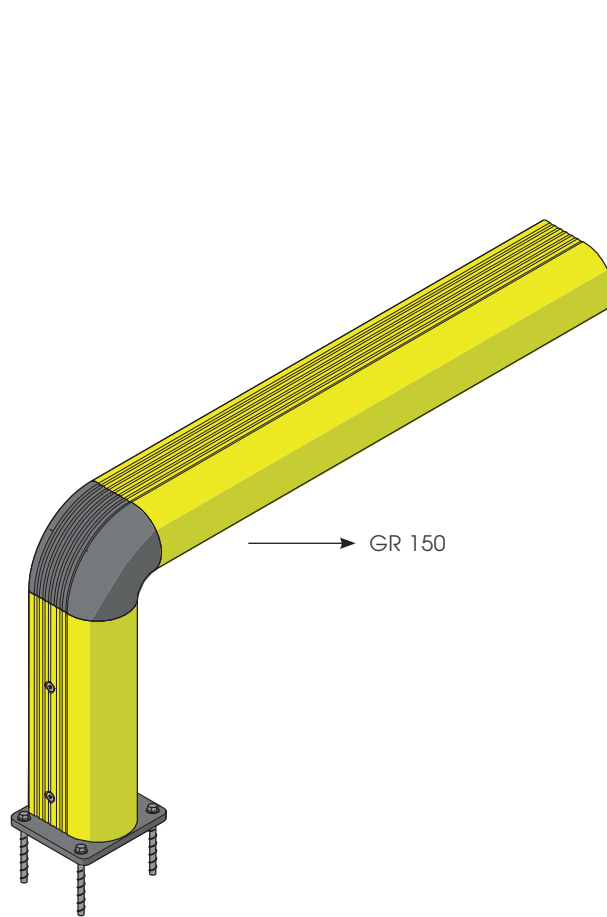

# FENCE 90/150/150 REINF.

ISTRUZIONI DI INSTALLAZIONE  
ASSEMBLY INSTRUCTIONS

